

REVISIONS			
REV	DESCRIPTION	DATE	APPROVED
--	--	--	--

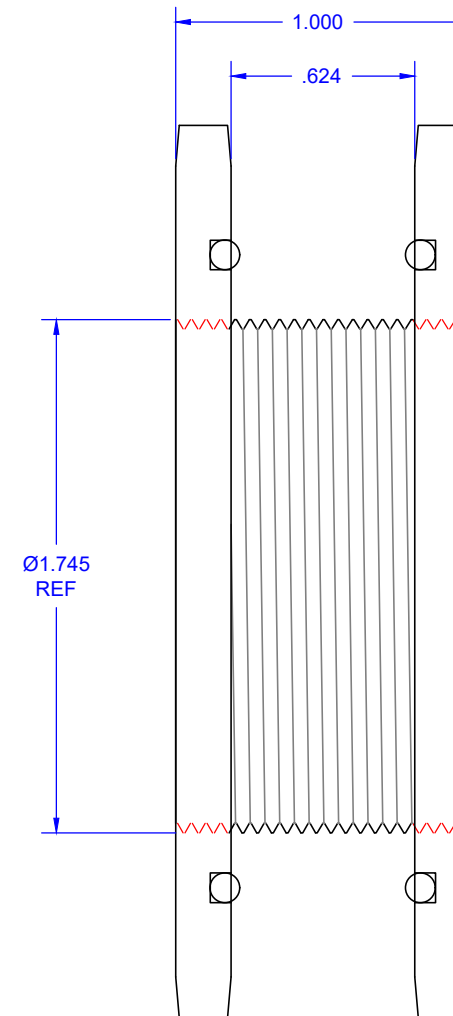
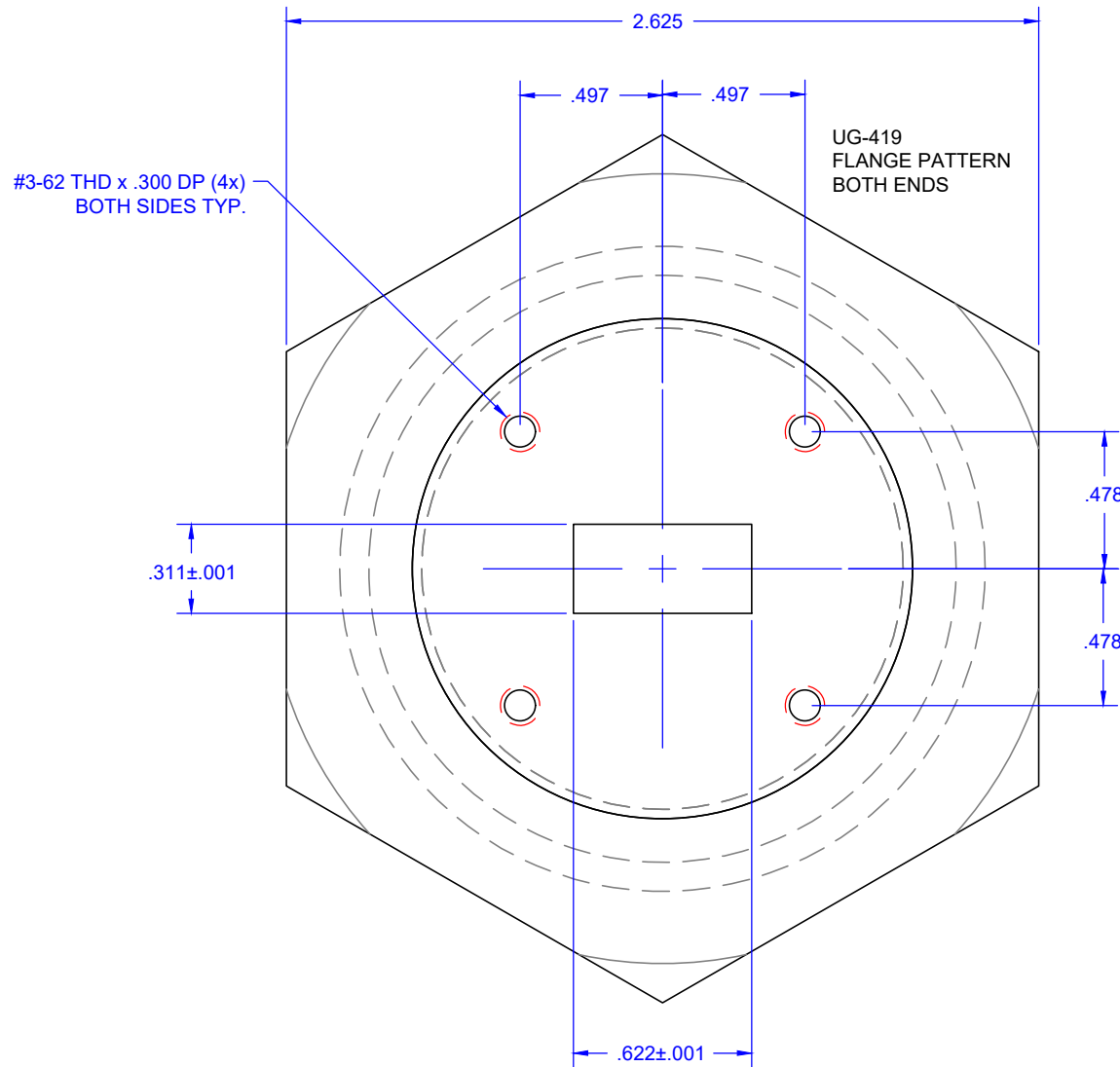

QTY	PART NUMBER	MATERIAL: 1/2 HARD BRASS		ITEM
UNLESS OTHERWISE SPECIFIED		 THIRD ANGLE PROJECTION		Mi-Wave Millimeter Products Inc. 712 KU_UG-419 OUTLINE
ALL SURFACES $\sqrt{32}$				
DIMENSIONS ARE IN INCHES TOLERANCES ARE: DECIMALS: .1234 +/- .0005 .123 +/- .005 .12 +/- .01 ANGLES: +/- .5 DEGREES		DRAFTING: JV APPROVED: M.S. DATE: 1-9-15		
ALL THREADS TO BE 2A OR 2B		SHEET NO.	OF	
REF DWG #: 10948		1	1	A
		DWG NO		22689